

## STAFFE PER MOLLA A DOPPIA SPIRA CLAMPS FOR DOUBLE SPIRAL SPRING TINE

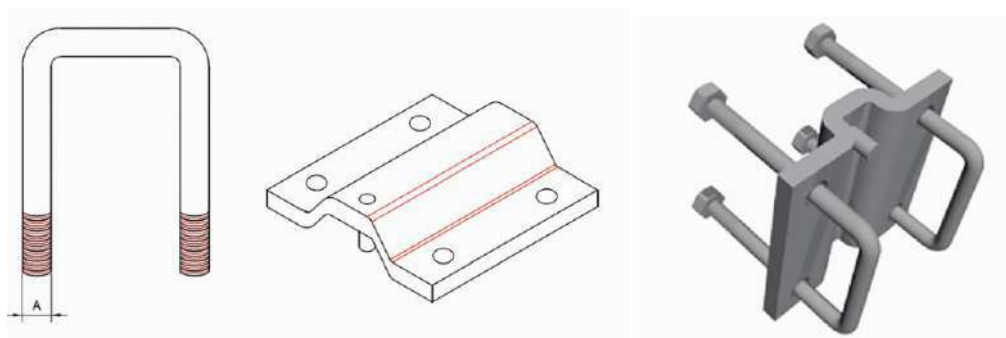

CODICE CODE	SEZIONE MOLLA mm. SPRING SECTION mm.	A mm.	TELAIO mm. FRAME mm.	PESO Kg. WEIGHT Kg.
07.00759	25x25	M 16	80x80	3
07.007591	30x30	M 16	80x80	3.5
07.00760	30x30	M 18	100x100	4
07.00761	35x35	M 18	100x100	4.5