

CILINDRI PER FRENI IDRAULICI / CYLINDERS FOR HYDRAULIC BRAKES

TIPO C-3 / C-3 TYPE

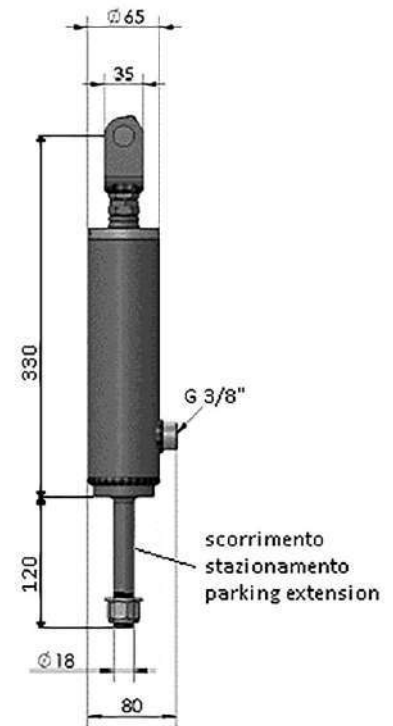

CODICE CODE	DESCRIZIONE DESCRIPTION	\varnothing STELO mm. \varnothing ROD mm.	CORSA mm. STROKE mm.	PESO Kg. WEIGHT Kg.
09.012031	GREZZO / RAW	28	90	5.10
09.0120310	VERNICIATO / PAINTED	28	90	5.10
09.0120311	GREZZO CON FORCELLA ASOLATA RAW WITH DRILLED FORK	32	90	5.50